

**SPECIFICATION SHEET**

# Oracle™ Collection

## 16" & 18" Stack Chair

The ORACLE chair bridges the gap between cutting-edge design and educational needs. Its core lies in the Dual Wall Shell Design, an ergonomic marvel featuring an Active Contour Seatback that cradles the user and a Compression Seat Zone for optimal pressure distribution. This, combined with the Pressure Sensitive Glide System, fosters active learning by intuitively adapting to diverse movements and floor surfaces, encouraging a natural weight shift towards the comfortable seatback and promoting optimal posture throughout the day.

Beyond ergonomics, the ORACLE chair prioritizes student well-being and inclusivity. Its High-Density Polyethylene (HDPE) construction is not just eco-friendly and highly recyclable, but also boasts excellent heat dissipation to ensure lasting comfort. The 4 Student Sitting Positions, coupled with the no pinch-point design, empower students to choose their preferred learning mode while ensuring safety and inclusivity.

- STACKS 4-5 HIGH
- BIFMA X6.1 CERTIFIED
- UV RESISTANT
- POWDER COATED 14-GAUGE 1" STEEL TUBE FRAME.
- PROPRIETARY COMPRESSION GLIDES SUITABLE FOR EVERY FLOORING TYPE.
- ECO-FRIENDLY AND HIGHLY RECYCLABLE HDPE SHELL.
- Designed for all grade levels and classroom environments.
- Easy to clean and maintain
- Backed by a comprehensive warranty.



Oracle 18"H Chair shown in Midnight Blue

**SPECIFICATIONS:**

	MODEL NUMBER	ORACLE 18S	ORACLE16S
<b>A</b>	SEAT HEIGHT	18"	16"
<b>B</b>	SEAT DEPTH	17"	17"
<b>C</b>	SEAT BACK WIDTH	17"	17"
<b>D</b>	SEAT BACK HEIGHT	33"	31"
<b>E</b>	FRAME WIDTH	20"	20"
<b>F</b>	FRAME DEPTH	21.5"	19"
	WEIGHT		

**DIMENSIONS:**

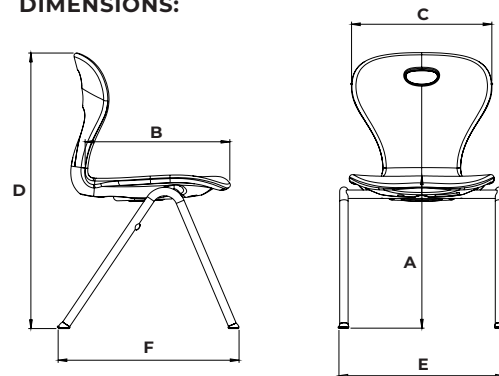

**SHELL COLORS:**

(Frame available in Platinum Powder Only)

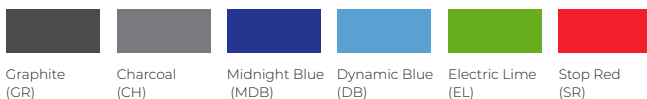

MADE IN USA



INNOVATIVE DESIGNS  
FOR CREATIVE SPACES.