



INNOVATIVE DESIGNS®
FOR CREATIVE SPACES

Assembly Instructions

Velocity Nest & Fold Table

Tools Required for Assembly:

- Hex Allen Keys supplied in hardware packs

Included Hardware:

- 4 - 3/8" X 3/8" Button Head Machine Screw
- 8 - 1/4" X 3/4" Button Head Machine Screw
- 4 - 3/8" Set Screw

Step by Step Assembly:

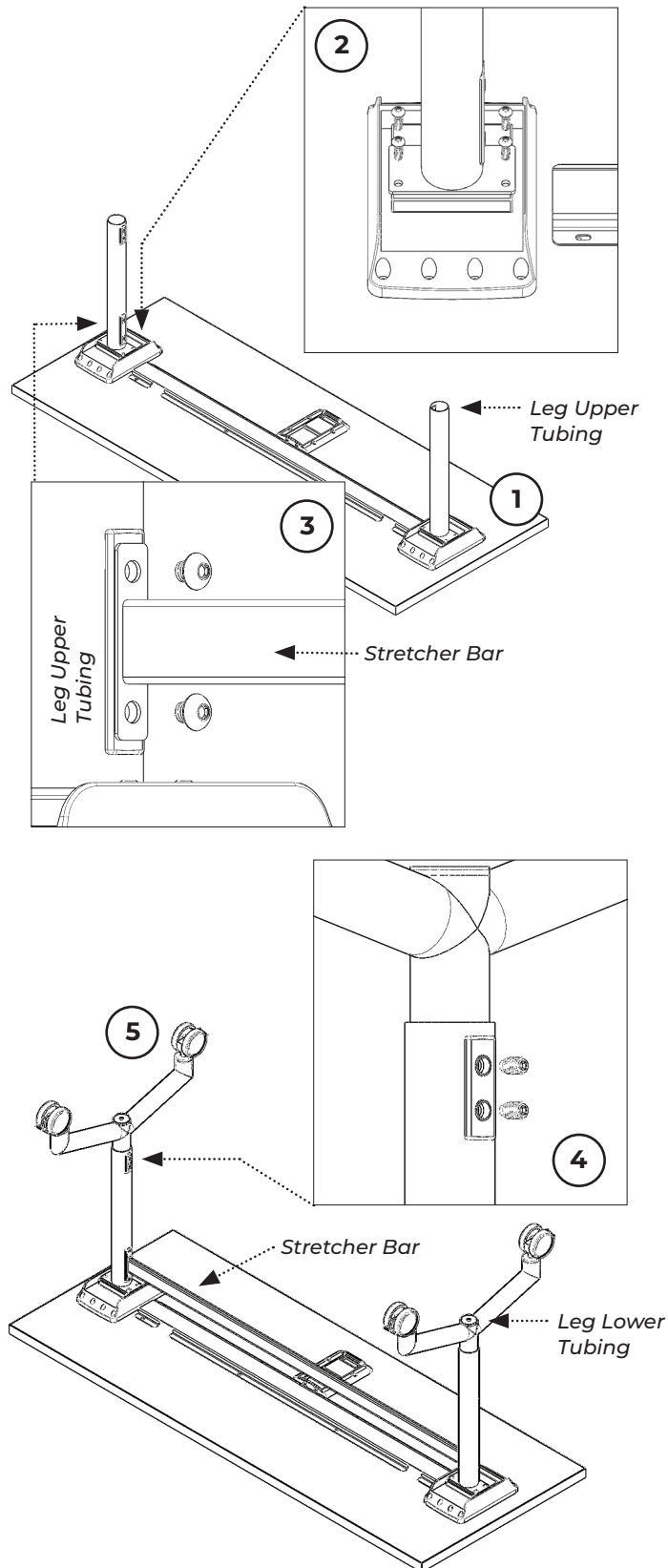

- 1 Lay Tabletop face down on a flat surface, using packaging box as a buffer between HPL laminate and floor. The Pre-installed Nest & Fold mechanism and wire-management tray should be facing up.
- 2 Install *Leg Upper Tubing* to the plate of the Nest & Fold mechanism using four (4) 1/4" screws per leg. Ensure the weld nuts used to attach the stretcher face toward the center of the table.
- 3 Install the stretcher in between the legs using four (4) 3/8" screws.
- 4 Install the Adjustable *Leg Lower Tubing* at the desired height (30" - 42" range) and fasten using two (2) 3/8" set screws per leg.
- 5 Install Casters into the threaded inserts at each end of the base.

FOR CUSTOMER SERVICE
1-800-999-0386 | ALLIEDUSA.COM